

FVT-1016 Vortex Flow Meters

Operation Manual

CONTENTS

Part I Manual-----1

Part II Model selecting & Installing for meter-----3

1. Ensure the diameter of meter-----3

2. Design & installation-----6

Part III Parameter set & pipeline design----- 10

1. Cable wiring-----10

2. Debugging and runningt -----10

3. Troubleshooting-----21

Part IV Appendix

Appendix I. Table of comparisons for saturation water-vapor density & platinum resistor-temp

Appendix II. Overheating- vapor density chart

Part I: Manul

1.Series

(LUGB/E)series is suitable for oil,chemical industry,metallurgy,heating power,spinning,papermaking ,etc. Be use of control: over-heating vapor, saturation vapor, compressed air, ordinary air(oxygen, nitrogen, hydrogen, natural gas, coal gas ,etc),water and liquid (water, petrol , alcohol, benzene ,etc.)

2.Working Principle

Non-streamline vortex-maker be set in fluid (anti-flow part) ,then two regular vortex would be come out ,from two sides of the vortex-maker in turn, so this kind of vortex be called as Karman vortex street, Chart I as follow.

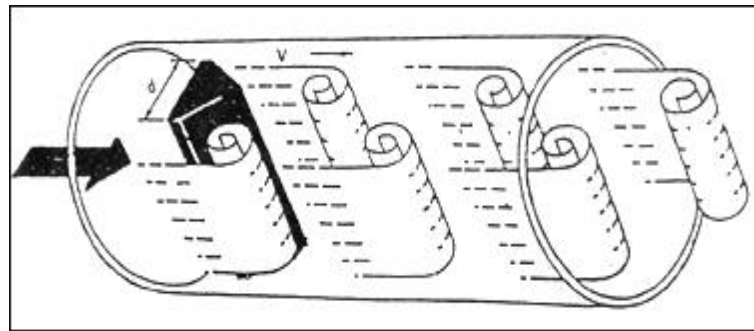

Chart I

Vortex is not flowing symmetrically under vortex-maker set .As if, set frequency of vortex is f ,the speed of test medium is V ,inlet face width of vortex-maker is d ,Past part diameter is D , as the principle of Karman vortex street ,as follow:

$$f = StV/d \quad (1)$$

Factor:

f —The Karman vortex street frequency which one side of vortex-maker

St —Strouhal number (dimensionless number)

V —mean flow rate

d —the width of vortex-maker

So, check the separate frequency of Karman vortex street to know the instant capacity(flow) .among, Strouhal number (St) is dimensionless number,

Chart II Show the relation of, Strouhal number (St) & Reynolds number (Re)

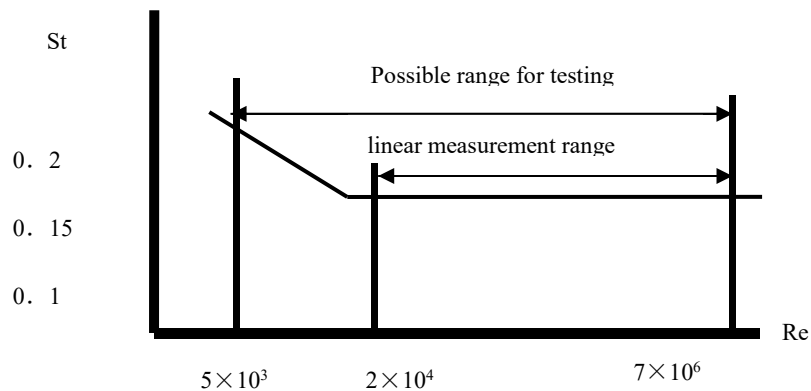

Chart II

Straightness part in curve($St=0.17$), free frequency & flow rate of vortex is direct ratio, it means flow sensor range. so just check out frequency (f), we can get the flow rate inside pipe, then as the flow rate(V) to take volume flow, the ratio record of impulse & volume, called as (K), as follow (2)

$$K=N/Q \text{ (1/m}^3\text{)} \quad (2)$$

Model: K =instrument constant (1/m³) .

N =impulse number

Q =volume flow (m³)

3. The key technical indexes

Inside nominal diameter (mm)	25, 40, 50, 65, 80, 100, 125, 150, 200, 250, 300, (300~1000 plug-in)
Nominal pressure (MPa)	DN25-DN200 4.0(>4.0 order by agreement) , DN250-DN300 1.6(>1.6 order by agreement)
Medium temperature (°C)	Piezoelectric type: -40~250, -40~320; Capacitance: -40~300, -40~400, -40~450 (Order by agreement)
Noumenon	1Cr18Ni9Ti,(Order by agreement if need other material)
Vibrating acceleration	Piezoelectric type:0.2g Capacitance:1.0~2.0g
Range	±1%R, ±1.5%R, ±1FS; Plug-in: ±2.5%R, ±2.5%FS
Range degree	1: 6~1: 30
Service voltage	Sensor: +12V DC,+24V DC; Transmitter: +12V DC ,+24V DC; Battery supply feed: 3.6V battery
Output signal	Square wave pulse (non- battery supply feed): high level≥5V, low level≤1V; urrent: 4~20mA
Loss coefficient	JB/T9249 Cd≤2.4
Anti-explosion sign	Ben-an type: Exd II ia CT2-T5 anti-explosion type: Exd II CT2-T5
Protection grade	Ordinary type IP65 Dive type IP68
Environment condition	Tem-20°C~55°C,Relative humidity 5%~90%,Atm press 86~106kPa
Medium	Gas、Liquid、Vapor
Transmission range	Three-wire system flow sensor: ≤300m, electric sign of two-wire system transmitter (4~20mA): load resistance≤750Ω

Part II : Model selecting & Installing for meter

It is important for selecting model, the key to use, so client must read this chapter carefully, and if find question, you can contact us.

I. Ensure the diameter of meter

According to the flow range to choose diameter. Different diameter hold different test range. Even if the same diameter, the test range is different if medium is not same. Practical test range must be confirmed by figure.

1.1 Flow range of air and water under reference condition, as chart II, reference condition as follow:

- 1). Air: Normal Temp & press, $t=20^{\circ}\text{C}$, $P=0.1\text{MPa}$ (absolute pressure), $\rho=1.205\text{ kg/m}^3$, $u=15\times 10^{-6}\text{ m}^2/\text{s}$.
- 2). Liquid : Normal temperature water, $t=20^{\circ}\text{C}$, $\rho=998.2\text{ kg/m}^3$, $u=1.006\times 10^{-6}\text{ m}^2/\text{s}$.

1.2 Basic step to ensure diameter of meter and flow range:

1). Working parameter clearly.

- (a) Name & component of testing medium
- (b) Min, Nor and Max capacity under working condition
- (c) Min, Nor & Max Press & Temp of medium
- (d) Viscosity of medium under working condition

2) . Meter test the flow capacity of medium under working condition, so as the technological parameter to know the flow capacity of medium under working condition, as follows:

- (a) If know air capacity under standard condition, we can get the capacity which under working condition, as follow;

$$Q_v = Q_o \times \frac{0.101325}{0.101325 + P} \times \frac{273.15 + t}{293.15} \quad \text{formula (3)}$$

- (b) If know air density under standard condition ρ_o , as follow;

$$\rho = \rho_o \times \frac{0.101325 + P}{0.101325} \times \frac{293.15}{273.15 + t} \quad \text{formula (4)}$$

- (c) Mass flow rate Q_m charge to volume flow Q_v

$$Q_v = Q_m \times 10^3 / \rho \quad \text{formula (5)}$$

Among formula(5):

Q_v : Volume flow of medium under working condition (m^3/h)

($Q_v=3600f/K$ K: Coefficient of meter)

Q_o : Volume flow under standard condition(Nm^3/h)

Q_m : Mass flow rate (t/h)

ρ : Density of medium under working condition(kg/m^3)

ρ_o : Density of medium under normal state(kg/m^3), common air medium density under normal state, as chart III

P : Gage pressure under working state (MPa)

t : Temp under working state($^{\circ}\text{C}$)

3). To ensure lower limit capacity. For the upper limit capacity of flow meter may be not counted under ordinary condition, so that just count its lower limit for choosing caliber. Shall meet two conditions: Minimum Reynolds number shall be not less than limited ($\text{Re}=2\times 10^4$); for vortex street flow meter with stress type set, it take vortex intensity from lower limit capacity shall be more than limited sensor intensity (vortex intensity and lift force, as scaling relation as ρv^2) . Relation as follow:

For density to test measurable lower limit flow:

$$Q_\rho = Q_o \times \sqrt{\rho_o / \rho} \quad \text{formula (6)}$$

For kinematic viscosity to test linear lower limit flow:

$$Q_v = Q_o \times \nu / \nu_o \quad \text{formula(7)}$$

medium:

Q_p : Meet request of vortex intensity, the minimum volume flow (m^3/h)

ρ_0 : Medium density under reference condition

Q_u : Meet request of Min-Reynolds number, the minimum linear volume flow (m^3/h)

ρ : The density of tested medium under working condition (m^2/s)

u_0 : Kinematic viscosity of medium under reference condition (m^2/s)

by means of formula (6) & (7) to come out Q_p &

Q_v : Compare with Q_p & Q_v , to ensure measurable range of lower limit flow & linear lower limit flow:

$Q_u \geq Q_p$: measurable range = $Q_p \sim Q_{max}$, linear flow range = $Q_u \sim Q_{max}$

$Q_u < Q_p$: measurable range & linear flow range $Q_p \sim Q_{max}$

Q_{max} : upper limit volume flow (m^3/h)

4). The standard of upper limit flow, See (II). gaseous upper limit flow velocity shall be less than 70m/s, liquid shall be less than 7m/s.

5). When tested gas is vapor, often use quality flow as unit of measurement quality flow, as: t/h or Kg/h. because of vapor (overheating & saturated), density would be changed under different temp & press, so to ensure the flow range, see (8)

$$Q_s = 1.5Q_a \times \rho \times 10^3 \times \sqrt{\rho_0 / \rho} \quad \text{formula (8)}$$

TIPS:

ρ : Density of vapor (kg/m^3)

ρ_0 : 1.205kg/m³

Q_s : Quality flow of vapor (t/h)

6). For pressure loss, check the effect of

working condition (kg/m^3)

Q_0 : Minimum volume flow of meter under reference condition (m^3/h)

u : Kinematic viscosity of medium under

pressure loss to craft pipeline, (Unit: Pa):

$$\Delta p = C_d \rho V^2 / 2 \quad \text{formula (9)}$$

Tips:

Δp : Pressure loss (Pa)

C_d : Coefficient of pressure loss

ρ : Density of medium under working condition (kg/m^3)

V : Mean flow rate (m/s)

7). If tested medium is liquid, to avoid 为 gasification and loss, shall make the press of pipeline as follow:

$$p \geq 2.7 \Delta p + 1.3 p_0 \quad \text{formula (10)}$$

Tips:

Δp : Pressure loss (Pa)

p_0 : Saturated vapor pressure of liquid which under working temperature.

(Pa absolute pressure)

P_0 : Fluidic vapor pressure

(Pa absolute pressure)

8). Vortex street flow meter is not suitable for testing high viscosity liquid. if counted measurable lower limit flow is not suitable for designing, pls select and use other meter type..

9). If as the counted parameter, the two or more kinds of meter can be used, then use less caliber, cheaper. Tips: as far as possible tested range during upper limit of about 1/2 ~ 2/3.

Table(I):Extent table of reference condition under working condition

Caliber (mm)	Liquid		Gas	
	Range(m ³ /h)	Output frequency range (Hz)	Measurement range (m ³ /h)	Output frequency range (Hz)
25	1.6~10	32~214	9~55	190~1178
40	2.5~25	13~130	22~200	115~1011
50	3.5~35	9~93	36~320	96~854
80	10~100	6~65	70~628	45~402
100	15~150	5~50	130~1100	43~367
150	40~350	4~33	280~2240	27~221
200	80~650	3~26	580~4200	24~167
250	120~950	3~19	970~5500	20~112
300	180~1800	2~22	1460~8000	17~95
(400)	180~3000	5.6~87	2750~27000	85~880
(500)	300~4500	5.6~88	4300~43000	85~880
(600)	450~6500	5.7~89	6100~61000	85~880
(800)	750~10000	5.7~88	11000~110000	85~880
(1000)	1200~17000	5.8~88	17000~170000	85~880
>(1000)	agreement		agreement	

Tips: above table the caliber (300)~(1000) is plug-in

Table(II):The density of common gas under normal state (0℃, absolute pressure P=0.1MPa)

Name	Density (kg/m ³)	Name	Density (kg/m ³)
Air(dry)	1.2928	Acetylene	1.1717
Nitrogen	1.2506	Ethylene	1.2604
Oxygen	1.4289	Propylene	1.9140
Argon	1.7840	Methane	0.7167
Ne	0.9000	Ethane	1.3567
Ammonia	0.7710	Propane	2.0050
Nydrogen	0.08988	Butane	2.7030
Carbon monoxide	1.97704	Natural gas	0.8280
Carbon dioxide	1.3401	Coal gas	0.8020

2. Design & installation

It is important to install meter, if not installed well, then would affect precision, use-life and damage.

2.1 Environmental request for installing:

- 1). To avoid strong current, high frequency and powerful switch set, power supply of meter shall be avoided to near by these equipments.
- 2). To avoid high-Temp & radiation source. if have to install it, need heat insulation & ventilated measure.
- 3). To avoid high-Temp & etchant gas, if have to install it, need ventilated measure.
- 4). Vortex street flow meter shall be avoided to install on shaking part of pipeline. if have to install on it, shall add clamp device and vibration pad which located on 2D to enhance shake proof . meter has better to installed indoors, pay attention to waterproof when installing meter outdoors, special notice the joint, make cable conductor to U shape to avoid water get into the amplifier body Around installing place shall save enough space, so that install connection line and maintenance routine.

2.2 Request for installing of pipeline meter:

- 1) .Vortex street-flow meter need a request for about installing point up-down stream pipe, if not flow field of medium will be affected in pipeline, refer to measurement accuracy of meter. up-down stream pipe of meter as chart(III)

DN is nominal caliber of meter

UNIT: mm

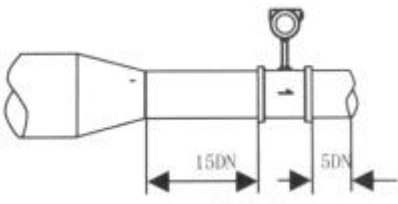
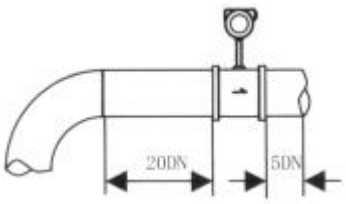
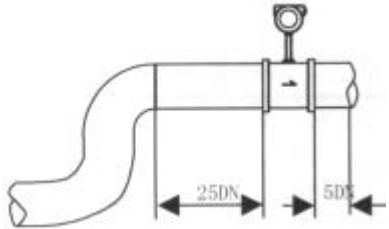
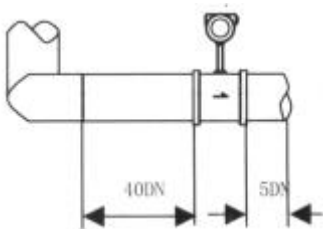
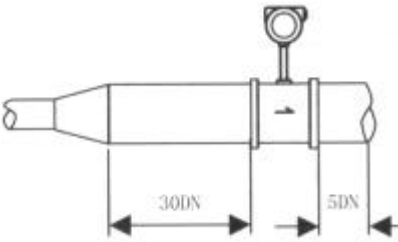
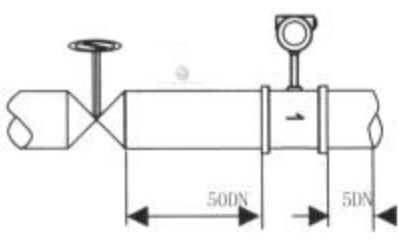
Sensor upstream pipe type	Front and back straight pipe length	Sensor upstream pipe type	Front and back straight pipe length
Concentric contract opening-valve		90 degree elbow	
Two 90 degree Elbow which on a same plane		Two 90 degree Elbow which not on a same plane	
Concentric expanded pipe		Control valve half open the vale (not recommend)	

chart(III)

Tips: control valve shall not install on upstream of meter, it better to the downstream 10D.

- 2). Up-down internal diameter of pipe shall be same. if not, than internal diameter of pipe D_p and vortex street meter inner diameter D_b , shall be as follow

$$0.98D_b \leq D_p \leq 1.05D_b$$

Up-down internal diameter of pipe shall be concentric with inner diameter of flow meter, The non- axiality

shall be less than $0.05D_b$.

3). Sealing gasket which between meter with flange, can not joint inside pipe when installing, and its inner diameter shall more than meter `s about 1~2mm.

4). Design for temp & press point. When test pipeline need install temp & pressure transmitter, pressure tap may be downstream of $3-5D$, thermometer hole may be downstream of $6-8D$, see chart (VII). D is nominal caliber, Unit: mm.

5). Meter can be installed by horizontal, vertical and bias ways on pipeline.

6). When test air, gas can flow anywhere when under uptake pipe to install. if there some air inside pipe ,to prevent liquid into the test pipe, so the air may from below to top, as list (IV) a.

7). When test for liquid, to ensure pipeline filled full, so install meter under vertical or bias working condition, shall ensure liquid flow from below to top. If there are some air inside of pipeline, meter may be installed under pipeline to prevent air into it.

As chart (IV) as follow:

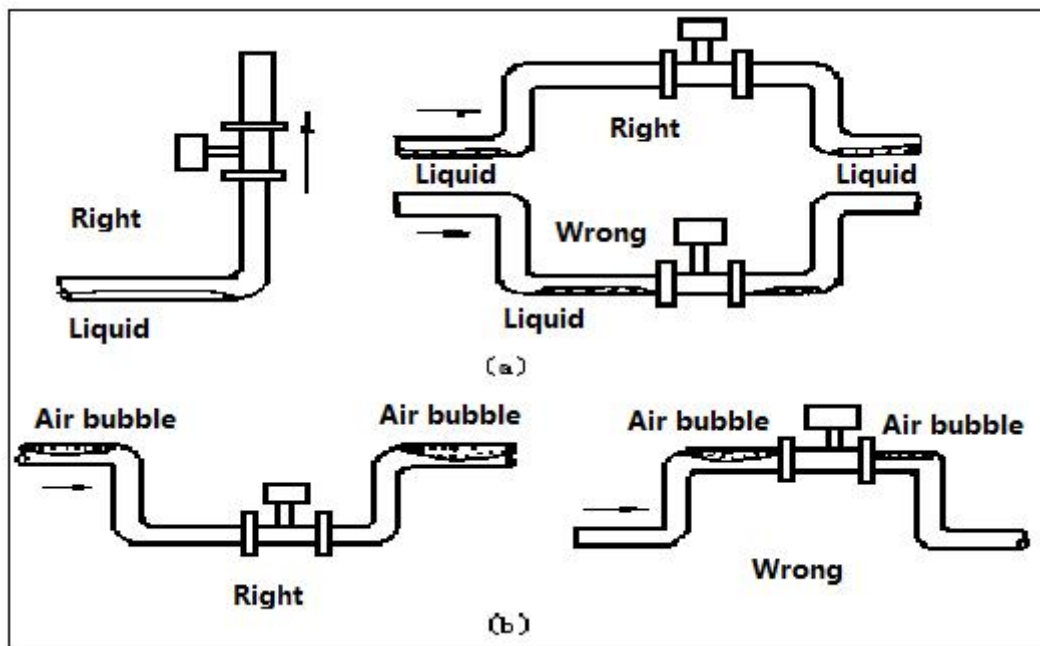

8). when test high& low temp medium, may pay attention to heat preservation. inside changer (inside body of gauge outfit) must be not more than 70°C ; if low temp inside will produce water into meter and reducing insulation.

2.3 Overall dimension installing of meter: SEE (V) & (VI)

2.3.1 Flange clamp type vortex flowmeter

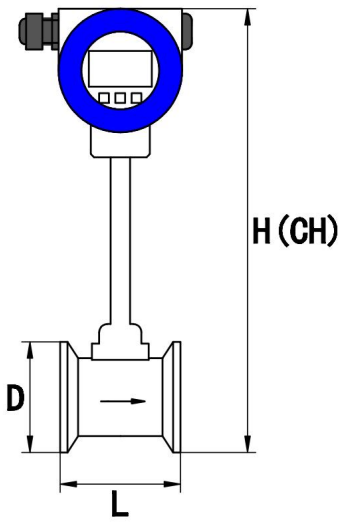

Chart (V)

DN (mm)	L	D	H	CH
15~25	70/90	54	325	385
32	85	69	325	385
40	85	79	325	385
50	85	89	330	390
65	85	104	340	400
80	90	119	360	420
100	90	139	380	440
125	95	168	405	465
150	100	194	430	490
200	102	248	485	545
250	115	300	540	600
300	130	350	590	650

2.3.2 Plug-in vortex flow meter

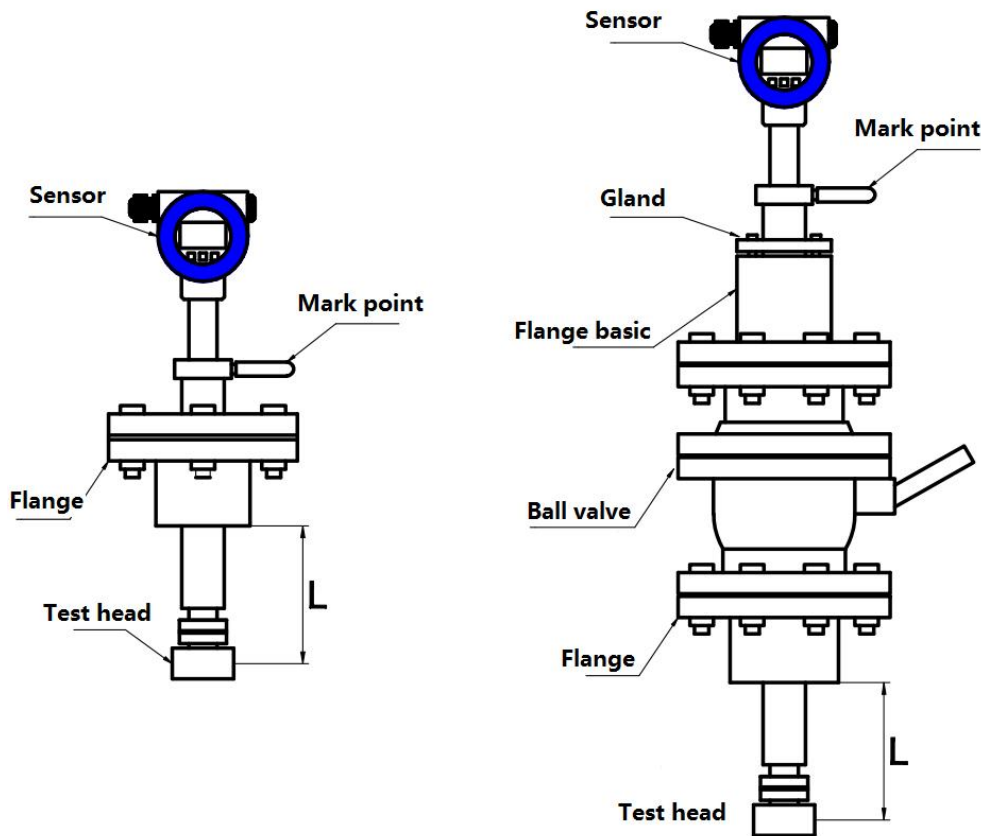

Chart (VI)

DN (mm)	DN250	DN300	DN400	DN500	DN600	DN800
L (mm)	125	150	200	250	300	400

2.4 The steps of installing plug-in vortex street meter:

- 1). Use gas welding to get a near $\phi 100\text{mm}$ circular hole, and clear it so that make the measuring head would be work fine.
- 2). The flange which from manufacturer would be burned-on round hole of pipeline.
- 3). Take ball valve and sensor install on the flange.
- 4). Balance screw, so that insertion depth is pass muster(ensure central axis dead in line between test head with pipeline), fluid flow direction must be stay the same with arrows.
- 5). Balance gland screw.(Notice: lead screw swirl and seal degree is decided to gland screw elasticity)
- 6). Check every steps, opening valve slowly to ensure leakage (take care of body), if find leakage, do step 5,6 once more.

2.5 Pt100 installing sketch map of PT100 and pressure transmitter

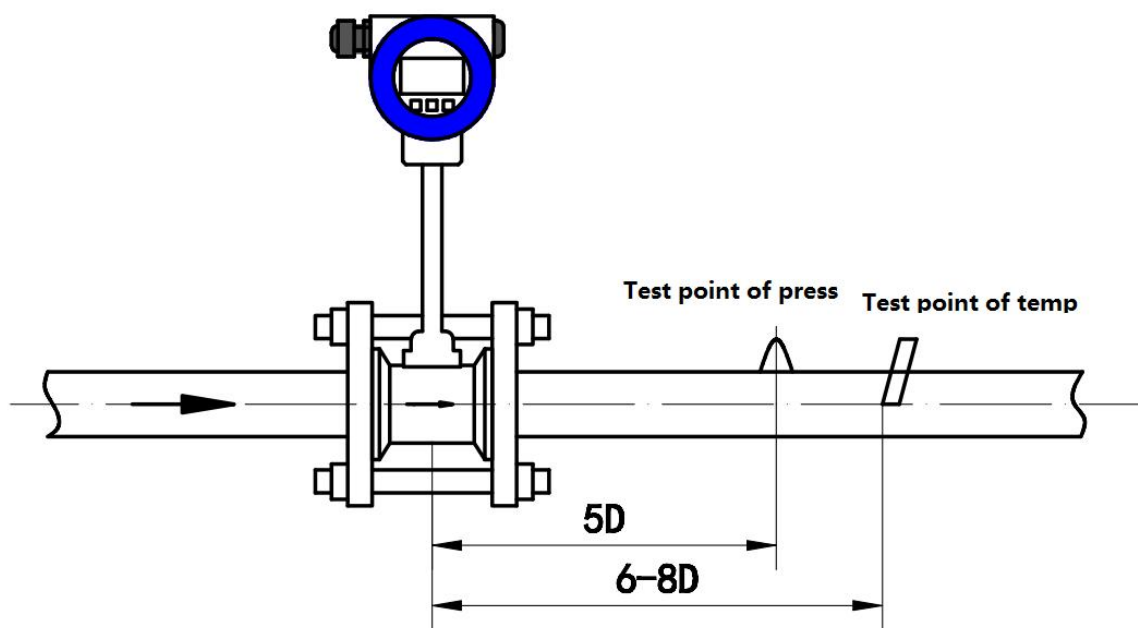

Part III: Parameter set & pipeline design

1. Cable wiring

- ◆ Do not operate with electricity
- ◆ Confirm the type and method of power supply

The company's products are divided into two types, according to different power supply methods, divided into battery power and 24V power supply.

wiring:

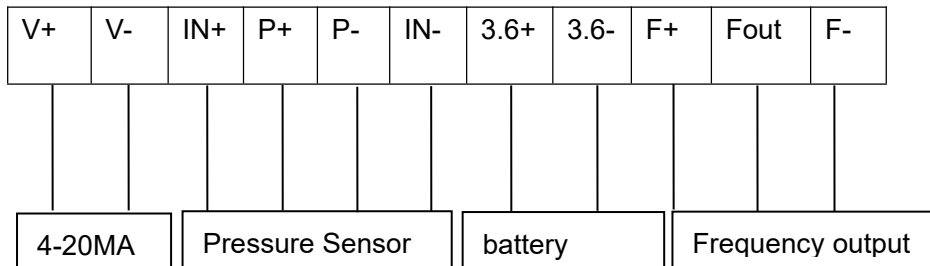

V+ V- is a two-wire current output port.

IN+ P+ P- IN- is the pressure sensor interface.

3.6+ 3.6- is the battery interface.

F+ F- is the frequency output power positive and negative interface here can be connected to 12V to 24V DC power supply, FOOUT is the frequency output interface.

Which part of the function is required to connect to the corresponding terminal.

2. Debugging and running

2.1 The appearance of the introduction

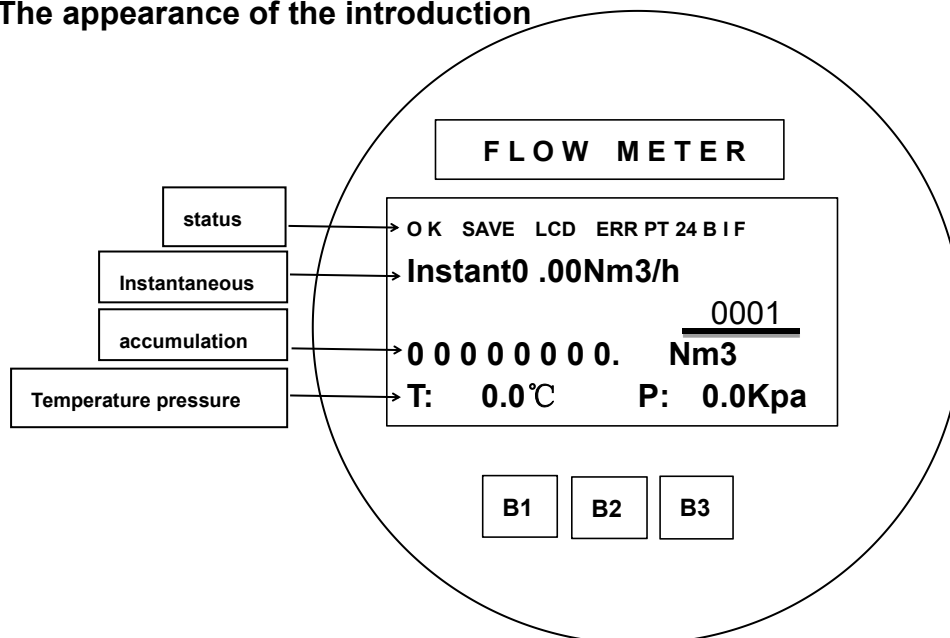

B1 is the SHIFT button, B2 is the Δ button, and B3 is the SET button.

2.1.1 Buttons The board can be found through the appearance of three buttons. Their functions are:

SHIFT: 1.Switch screen. You can switch to the menu screen by pressing this on the main interface.

2.Switch the menu item and press this button on the menu screen to switch between different menus.

3. Shift key, in the parameter setting, you can use this button to shift.

4. Exit, in the parameter setting, press this button to exit the menu item without the displacement item.

Δ: The digital item plus function can adjust the number of the number according to the item that can input the number. The number size can be displayed cyclically. For example, if the current display is 6, it can be displayed as 8 for 2 times, or 1 for 3 more times.

SET: 1.confirm the function, mainly after modifying the parameters, press this button to confirm the parameters.

2.Switch the menu. In the parameter setting, press this key directly to switch to other parameters, and the parameter list is displayed cyclically.

2.1.2 Display

1. The prompt line is displayed in the upper left corner: OK, SET and SAVE are displayed in normal condition. If there is obvious error in the parameter, ERR will be displayed. PT 24 BIF stands for circuit board function, PT stands for temperature compensation, 24 stands for 24V output, B stands for battery Power supply, I stands for two-wire current output, F stands for frequency output, and 485 stands for 485 output. The representative of the display has this function.

2. The second row shows the instantaneous value: it consists of the instantaneous prompt word, the instantaneous value and the current unit.

3. The third row shows the accumulated value: it consists of the integral part of the accumulated value, the accumulated fractional part of the four digits and the unit.

4. The fourth row is the temperature and pressure state: the left side is the temperature mark, the temperature value and the temperature unit composition, and the right side is the pressure mark, the pressure value and the pressure unit.

2.2 Parameter settings

2.2.1 Main page display

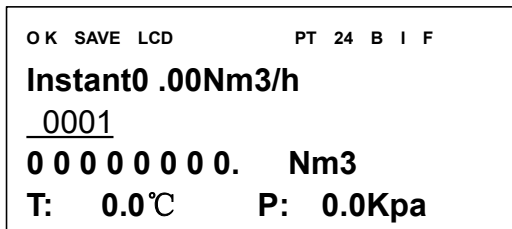

In this interface, press the SHIFT key to enter the setup menu.:

2.2.2 Parameter setting main interface

Press the SHIFT (Shift Select Menu) button

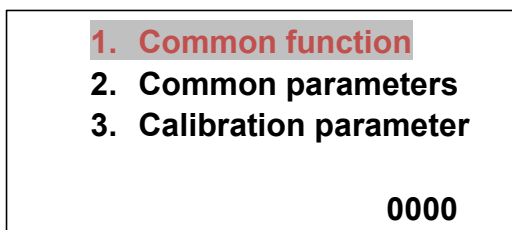

In the main interface, press the SHIFT key to enter the main menu interface. You can use the SHIFT button to select the corresponding menu item and press the SET button to enter.



Language
English



Alg
Conventional volume



unit
Nm3/h



Fmin
HZ
00000



Fmax
HZ
00000



Flow Coefficient
 ρ/m^3
3600



Full flow
00001000.0000



In the main menu of the main interface, press the SET button to enter the common menu interface. Press the SET button to save and go to the next menu, press the SHIFT button to move the cursor position, and the arrow keys to modify the parameters.

Under the language menu, press the SET button to save and enter the algorithm menu. Press the SET button to save and go to the next menu, press the SHIFT button to move the cursor position, and the arrow keys to modify the parameters.

Under the Algorithm menu, press the SET button to save and enter the Units menu. Press the SET button to save and go to the next menu. Use the arrow keys to modify the unit.

Under the unit menu, press the SET button to save and enter the calibration lower limit menu. Press the SET button to save and go to the next menu, press the SHIFT button to move the cursor position, and the arrow keys to modify the parameters.

Under the calibration lower limit menu, press the SET button to save and enter the calibration upper limit menu. Press the SET button to save and go to the next menu, press the SHIFT button to move the cursor position, and the arrow keys to modify the parameters.

Under the calibration upper limit menu, press the SET button to save and enter the flow coefficient menu. Press SET to save and enter the next menu, press SHIFT to move the cursor position, arrow key to modify the parameter, the coefficient is proportional to the flow, the coefficient is the total coefficient.

In the Flow Factor menu, press the SET button to save and enter the full flow menu. Press the SET button to save and go to the next menu, press the SHIFT button to move the cursor position, and the arrow keys to modify the parameters.

Density
Kg/m³
1000.000



T
°C
000.0



P
Kpa
000.0



Lower cut
HZ
000.0



Flow clear
clear



password
0000



0SET
00



Under the Full Flow menu, press the SET button to save and enter the Density menu. Press the SET button to save and go to the next menu, press the SHIFT button to move the cursor position, and the arrow keys to modify the parameters. When quality is required, you can check the standard density to enter the menu.

Under the density setting menu, press the SET button to save and enter the temperature setting menu. Press the SET button to save and go to the next menu, press the SHIFT button to move the cursor position, and the arrow keys to modify the parameters.

Under the temperature setting menu, press the SET button to save and enter the pressure setting menu. Press the SET button to save and go to the next menu, press the SHIFT button to move the cursor position, and the arrow keys to modify the parameters.

Under the gauge pressure setting menu, press the SET button to save and enter the lower cut menu. Press the SET button to save and go to the next menu, press the SHIFT button to move the cursor position, and the arrow keys to modify the parameters.

Under the lower cut menu, press the SET button to save and enter the clear menu. Press the arrow keys to clear the cumulative flow.

Under the clear menu, press the SET button to save and enter the password setting menu. Press the SET button to save and go to the next menu, press the SHIFT button to move the cursor position, and the arrow keys to modify the parameters.

In the password setting menu, press the SET button to save and enter the zero anti-vibration menu. Press the SET button to save and go to the next menu, press the SHIFT button to move the cursor position, and the arrow keys to modify the parameters.

Backlight



Rate



mailing address
00



O K SAVE LCD P T 24 B I F
Instant0 .00Nm3/h
0001
0 0 0 0 0 0 0 0. Nm3
T: 0.0°C P: 0.0Kpa



1.Common function
2.Common parameters
3.Calibration parameter
0000



F: 0.000HZ
Overflow: 0



O K SAVE LCD P T 24 B I F
Instant0 .00Nm3/h
0001
0 0 0 0 0 0 0 0. Nm3
T: 0.0°C P: 0.0Kpa

Under the zero anti-vibration menu, press the SET button to save and enter the backlight menu. Press the SET button to save and go to the next menu. Press the SHIFT button to move the cursor position and the button to modify the parameters.

Under the backlight menu, press the SET button to save and enter the speed menu. Press the SET button to save and go to the next menu, press the SHIFT button to move the cursor position, and the arrow keys to modify the parameters.

Under the backlight menu, press the SET button to save and enter the speed menu. Press the SET button to save and go to the next menu, press the SHIFT button to move the cursor position, and the arrow keys to modify the parameters. Here is the last menu, press the SET button to automatically return to the main interface, if there is no 485 communication without this menu.

In the main interface, double-click to select the common parameter query.

In this interface, press the SET button to enter the common parameter query menu.

Under the Query menu, press the SET button to save and re-enter the main page display. The overflow flag is 1 when the flow rate exceeds 100000000. When this bit is greater than 10, it is automatically cleared. When the accumulated flow is cleared, this bit is also cleared. Press the SET button under this menu to return to the main page.

In the main interface, press three times to select the calibration parameter settings.

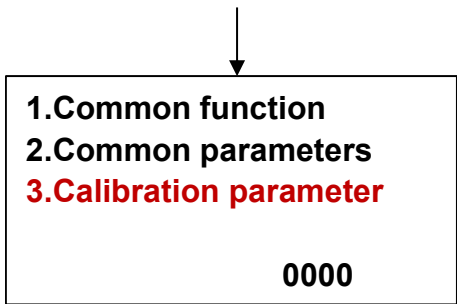

In this interface, press the SET button to enter the calibration parameter password input, enter the fixed password to enter the system calibration menu, the menu option prohibits the user from arbitrarily changing.

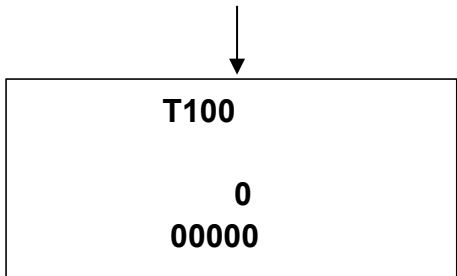

Under the password menu, press the SET button to enter the PT100 menu. Press the SET button to save and go to the next menu, press the SHIFT button to move the cursor position, and the arrow keys to modify the parameters.

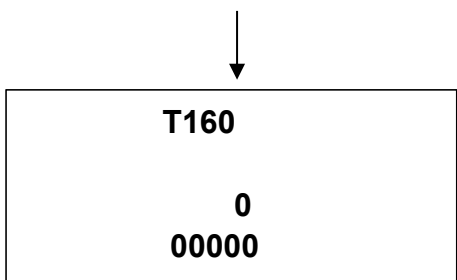

Under the T100 menu, press the SET button to enter the T160 menu. Press the SET button to save and go to the next menu, press the SHIFT button to move the cursor position, and the arrow keys to modify the parameters.

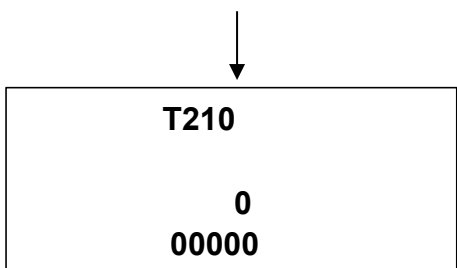

Under the T160 menu, press the SET button to enter the T210 menu. Press the SET button to save and go to the next menu, press the SHIFT button to move the cursor position, and the arrow keys to modify the parameters.

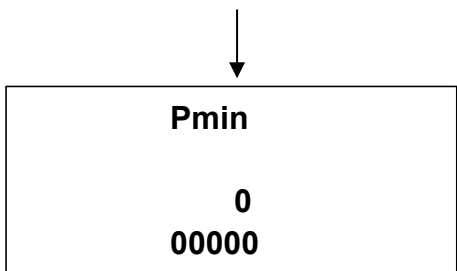

Under the T210 menu, press the SET button to enter the Pmin menu. Press the SET button to save and go to the next menu, press the SHIFT button to move the cursor position, and the arrow keys to modify the parameters.

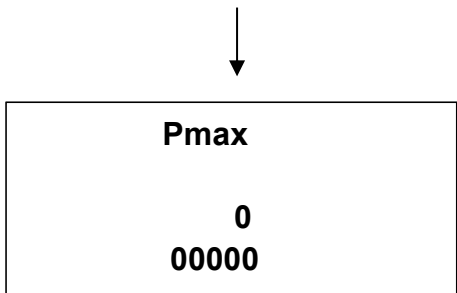

In the Pmin menu, press the SET button to enter the Pmax menu. Press the SET button to save and go to the next menu, press the SHIFT button to move the cursor position, and the arrow keys to modify the parameters.

Pran
01600



Pran
01600



P+



4mA
4.0000



20mA
20.0000



Reset



PT100



In the Pmax menu, press the SET button to enter the Pran menu. Press the SET button to save and go to the next menu, press the SHIFT button to move the cursor position, and the arrow keys to modify the parameters.

In the Pmax menu, press the SET button to enter the Pran menu. Press the SET button to save and go to the next menu, press the SHIFT button to move the cursor position, and the arrow keys to modify the parameters.

Under the Pran menu, press the SET button to enter the P+ menu. Press the SET button to save and go to the next menu, press the SHIFT button to move the cursor position, and the arrow keys to modify the parameters.

Under the P+ menu, press the SET button to enter the 4 mA menu. Press the SET button to save and go to the next menu, press the SHIFT button to move the cursor position, and the arrow keys to modify the parameters.

In the 4 mA menu, press the SET button to enter the 20 mA menu. Press the SET button to save and go to the next menu, press the SHIFT button to move the cursor position, and the arrow keys to modify the parameters.

Under the 20 mA menu, press the SET button to enter the Reset menu. Press the SET button to save and go to the next menu, press the SHIFT button to move the cursor position, and the arrow keys to modify the parameters.

In the Reset menu, press the SET button to enter the PT100 menu. Press the SET button to save and go to the next menu, press the SHIFT button to move the cursor position, and the arrow keys to modify the parameters.

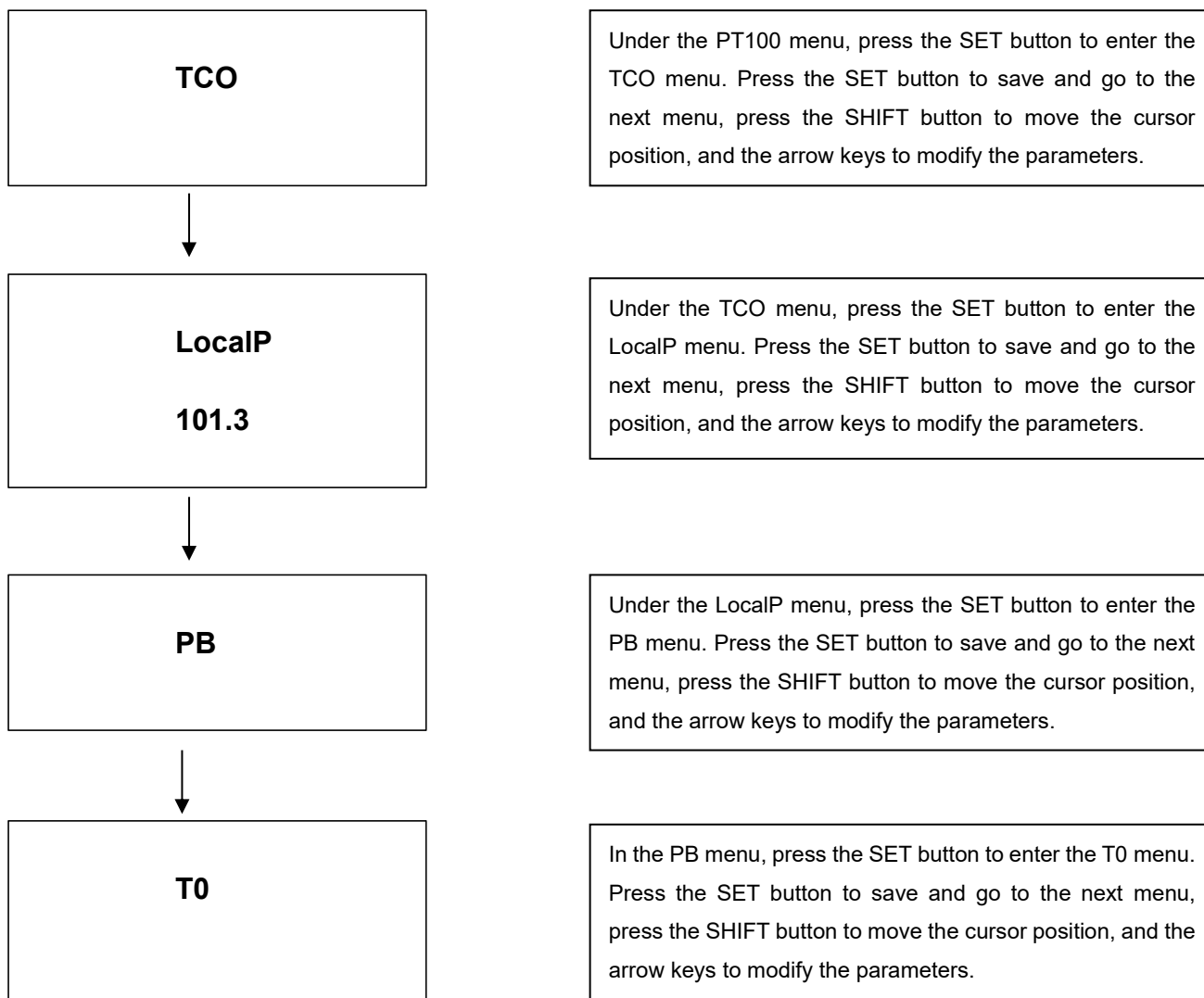

2.2.3 Common function settings:

Menu name	Parameter value	meaning
Language	0: Chinese 1: English	Set the instrument language
algorithm	Volume (working conditions for volume) STPV (quality of work conditions) MASS(standard volume) STPm (standard quality) Tcomp (saturated steam) Pcomp(saturated steam) PT comp(superheated steam)	Different algorithms are used depending on the medium and the unit selected.
unit	m ³ /h; m ³ /m; l/h; l/m Nm ³ /h; Nm ³ /m; NL/m t/h; kg/m; kg/h	The unit of the fluid to be displayed, the unit must match the algorithm.
Fmin	0	For calibration of multi-segment coefficients, the default is 0, and the lower limit must be less than the upper limit.

Fmax	0	4 upper limit values, calibration upper limit 0 and 1 setting 2 and 3 are 0, then 3 points are calibrated, and the upper limit of calibration 0, 1, 2, 3 is set to 5 points.
Flow Coefficient	3600	The flow meter factor required to calculate the flow rate, where the four coefficients correspond to the four-stage calibration of the upper and lower calibration limits.
Full flow	1000	Set the instantaneous flow rate corresponding to the full scale at 20mA current output (not allowed to be set to 0). The unit is the same as the unit selected in Unit Selection.
Density	1000	Set the density value of the fluid in units of kg/m ³ (not allowed to be set to 0) (quality algorithm needs to calculate the density value of this setting, it does not work for volume class algorithm and steam algorithm)
T	0000	It is used to set the temperature when setting. If the connected sensor automatically collects this menu and the pressure setting menu must be 0 at the same time, if one item is not 0, it will become the fixed value calculation.
P	0000	It is used to set the pressure when setting. If the sensor is automatically collected, this menu and temperature setting menu must be 0 at the same time. If one item is not 0, it will become the fixed value calculation. (Note here is the gauge pressure).
Lower cut	10	The setting is lower than the set frequency and the flow is not displayed (used to eliminate interference caused by environmental conditions when static).
Flow clear	clear	Clear accumulated traffic.
password	0010	Used to set the password to enter the parameter menu, the site administrator can modify the password to prevent malicious tampering with parameters.
OSET	00	It is used to filter out the vibration interference of the zero point of the instrument. It must be set to 00, otherwise there may be no flow display.
Backlight	0	Set to 1 backlight to turn on, set to 0 backlight to turn off
Rate	0	Set to 1-bit filtering algorithm for field flow instability

2.2.4 Calibration parameter settings:

Note: The following menus are not allowed for private transfer by non-professionals. Private transfer may result in inaccurate temperature.

Menu name	Parameter meaning
T100	PT100 100 ohm calibration The PT1000 is set to 1000 ohms for the variable resistance box. Using the high and low precision AD conversion chip AD7705, the error of 3-4 ° C can be guaranteed without calibration, and the error after calibration is less than or equal to 0.5 ° C.
T160	The variable resistance box is calibrated to 160 ohms. The PT1000 corresponds to the 1600 ohms corresponding to the variable resistance box.
T210	The variable resistance box hits 210 ohm calibration. The PT1000 corresponds to the variable resistance box setting corresponding to 2100 ohms.
P min	Pressure zero check value.
P max	Pressure full scale check value.
P ran	Pressure range.
P+: 0	Pressure mode, positive or negative pressure, used for negative pressure setting at constant pressure.
4mA: 4.0000	Calibrate 4 mA. This menu must be re-set to 4 for calibration. The high-precision 16-bit DA conversion chip AD421 is used, which is more accurate than the general multimeter. The customer does not require special calibration.
20mA: 20.000	Calibrate 20 mA. This menu must be reset to a parameter of 20 for calibration. Ibid.
PT100/PT1000	Temperature sensor selection
Tco	Temperature linear correction, the default is 50. For example, if the main interface is 100 ° C, the standard is 101 ° C, here is set to 51, if the standard is 99 ° C, set here to 49.
LocalP	Local atmospheric pressure setting.
PB/PJ	PB is a gauge pressure sensor, PJ is an absolute pressure sensor
T0/T20	T0 is the standard gas volume of 0 ° C an atmospheric pressure, T20 is 20 ° C, used for the calculation of the standard gas volume flow. Generally, natural gas is 20 ° C standard, others are 0 ° C.

2.2.5 The dial switch settings

The vortex flowmeter adjusts the performance of the instrument with different calibers by adjusting the dial switch. In the vortex flowmeter, there are 5 sets of dial switches, which are located on the main board below the display screen, and are marked with GB (4 groups) and SB (4 groups), K1, K2, K3 printed lettering

GB and SB are four groups of dialing codes, the function of which is signal gain, which can be simply understood as sensitivity. The normal factory GB is 1, 2 is on, SB is 3 is on, the meaning is

Dial code	1	2	3	4
value	1	2	4	8

In normal use, the sum of the values corresponding to the dialing bits is used, and the larger the value, the higher the sensitivity. The functions of .K1, K2 and K3 are signal filtering, and each of their meanings is different. Here, the common caliber and medium corresponding setting values are provided. Of course, due to the difference in the meter itself, it may be slightly different from the table below.

Liquid			
Caliber	K1	K2	K3
15	1357	5	123
20	1357	5	123
25	1357	5	4
32	1357	5	4
40	1458	7	1234
50	1458	7	5
80	1458	67	45
100	1458	67	6
125	1458	8	7
150	1458	8	7
200	48	8	8
250	3478	78	78
300	3478	78	78

Gas			
Caliber	K1	K2	K3
15	1256	1	1
20	1256	1	1
25	1256	2	2
32	1256	2	2
40	1357	2	2
50	1357	2	3
80	1357	3	13
100	1357	3	123
125	1357	4	123
150	1357	4	4
200	1458	5	4
250	1458	6	1234
300	1458	7	5

3.Troubleshooting

Fault	Cause	Solution
No output signal after power on	<ol style="list-style-type: none"> 1. No fluid flowing or the flow rate is under starting flow. 2. The connections of power supply and output are incorrect. 3. The pre-amplifier is damaged (The calculator can't count, and the flow rate is 0). 4. The circuit of driving amplifier is damaged (The display of calculator is normal). 	<ol style="list-style-type: none"> 1. Increase the flow rate or replace a flow meter with smaller nominal diameter to meet the requirement of flow range. 2. Make the connection correct. 3. Replace the pre-amplifier. 4. Replace the damaged components in the circuit of driving amplifier.
The meter outputs signal when no flow	<ol style="list-style-type: none"> 1. The interference of bad grounding of meter, strong electricity and interference of other grounding. 2. The higher sensitivity of amplifier or it may produce self excitation. 3. Unstable power supply, bad filtering or other electrical disturbance. 	<ol style="list-style-type: none"> 1. Make the grounding well 2. Replace the pre-amplifier. 3. Repair or replace the power supply.
Unstable display of flow rate	<ol style="list-style-type: none"> 1. Unstable flow in pipe 2. The higher or lower sensitivity of amplifier make the output pulses are more counted or less counted. 3. There is debris in the shell of meter. 4. Bad grounding. 5. The flow rate is under the low limit. 6. The downstream seal ring reaches into pipe, and make disturbance. 	<ol style="list-style-type: none"> 1. Begin to measure after the flow rate is stable. 2. Replace the pre-amplifier. 3. Remove the debris. 4. Check the grounding, make the grounding well.
The displayed total flow is inconsistent as actual total flow	<ol style="list-style-type: none"> 1. The flow coefficient of meter is incorrect. 2. The flow rate on site is higher than the maximum flow of meter. 3. The bad quality of the flow meter. 	<ol style="list-style-type: none"> 1. Recalibrate the meter and input the new flow coefficient. 2. Reduce the flow rate in pipe or replace the flow meter. 3. Recalibration
Abnormal display	Bad contact of the key or dead lock the key	Replace the display board.
System halts after replacement new battery	The electrify reset circuit is abnormal, or the oscillating circuit can't afford to boost.	Reinstall the battery (Before reinstall the battery, the meter is needed to discharge more than 5 seconds)